

# Installation Guide

## TxWireless EDGE IG20

Industrial IoT Gateway  
and software platform



# TxWireless EDGE IG20

## Installation Guide

---

<b>1. INTRODUCTION</b>	<b>3</b>
<b>2. INSTALL GATEWAY</b>	<b>4</b>
STEP 1/4: TURN ON BATTERY	4
STEP 2/4: MOUNT GATEWAY	4
STEP 3/4: MOUNT AND CONNECT ANTENNAS	5
STEP 4/4A: CONNECT GATEWAY TO MODBUS ASSET USING RS485	6
STEP 4/4B: WIRE ASSET CONTROLLER FOR CAN BUS	6
<b>3. ADDITIONAL SENSORS</b>	<b>7</b>
OPTION 1: WIRE ASSET CONTROLLER TO CONNECT ANALOG SENSORS	7
OPTION 2: WIRE ASSET CONTROLLER TO CONNECT DIGITAL INPUTS	7
OPTION 3: WIRE ASSET CONTROLLER TO CONNECT DIGITAL OUTPUTS	7
OPTION 4: WIRE ASSET CONTROLLER TO CONNECT RS232	8
OPTION 5: WIRING OPTIONS FOR ONBOARD RELAY	8
<b>4. LED INDICATORS</b>	<b>9</b>
<b>5. TERMINATION SWITCHES</b>	<b>11</b>
RS485 TERMINATION RESISTOR	11
CAN BUS TERMINATION RESISTORS	12
<b>6. APPENDIX</b>	<b>12</b>
6.1 SECURITY	12
6.2 SAFETY AND REGULATORY REQUIREMENTS	13
FEDERAL COMMUNICATION COMMISSION INTERFERENCE STATEMENT	13
RF EXPOSURE INFORMATION (SAR)	14
NOTICES	14

# 1. Introduction

The **TxWireless EDGE Industrial Gateway** empowers your enterprise with real-time insights and intelligence to drive cost savings, revenue growth, and enhanced compliance. This next-generation IoT device boasts cellular, and on-board sensor capabilities, seamlessly integrated with a cloud-based connectivity and device management platform.

## 1.1 What's included?

On receipt of your **TxWireless EDGE Industrial Gateway** the following items should be included in the pack:

1. A **TxWireless EDGE IG20** industrial gateway
2. Optional with some IG20 Series Gateway you may receive a separate package with the **Taoglas MA114 antenna** that corresponds to your kit.



For **IG20 User Guide** please see **TxWireless EDGE IG20 User Guide**

For **MA114 Installation Instructions** support please see **Taoglas MA114 Installation Guide**

For **MA114 antenna datasheet** please see <https://www.taoglas.com/datasheets/MA114.pdf>

## Support

For technical support please contact [support@txwireless.com](mailto:support@txwireless.com)

1. Go to <https://www.txwireless.com/service/edge-ig20/> to access
  - a. Datasheet
  - b. User Guides

---

## 2. Install Gateway

### Step 1/4: Turn on Battery

Before mounting the unit, it is essential to activate the internal battery:

1. Remove the **Remove this Label to operate Battery Switch** label.

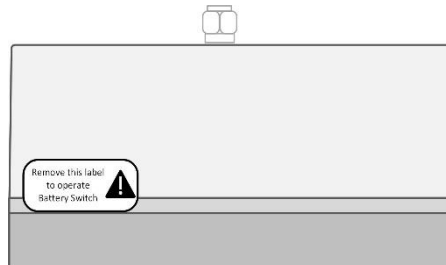

2. Slide the battery cutoff switch all the way to the right to the **ON** position.

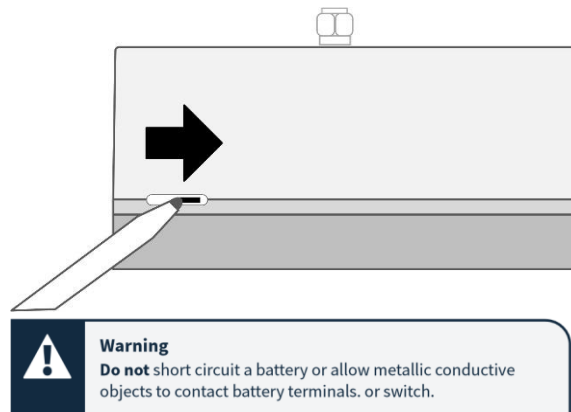

### Step 2/4: Mount Gateway

The **TxWireless EDGE IG20** offers two mounting options.

1. The DIN rail connector located on the back of the enclosure.
2. The four fixing holes.

To mount the **TxWireless EDGE IG20** onto a DIN rail, simply clip it onto the rail.

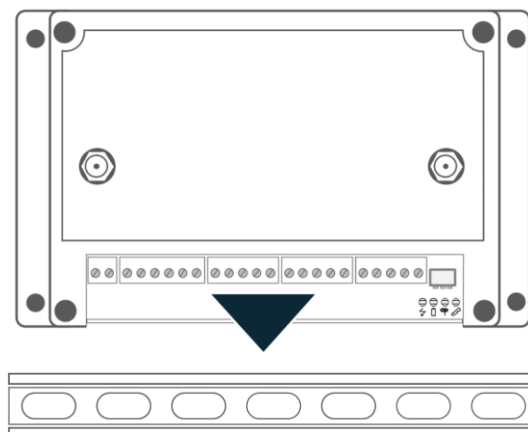

**Note:** The gateway can be removed from the DIN rail by **pulling on the two red tabs** on top of the gateway.

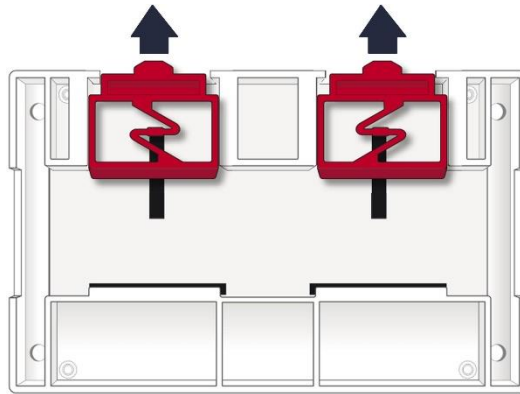

To mount the **TxWireless EDGE IG20** directly to a structure, use the four fixing holes.

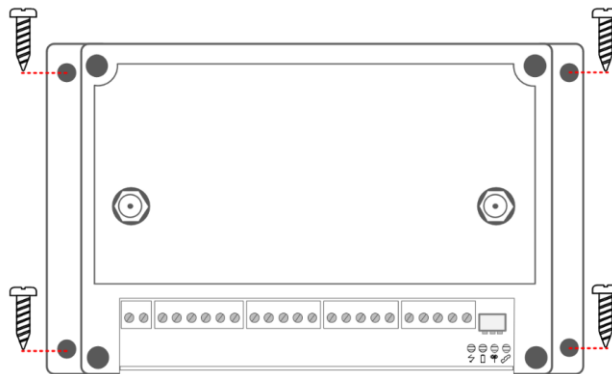

### Step 3/4: Mount and Connect Antennas

Mount the Taoglas® antennas and route both cables to the gateway as follows:

1. Connect the **LTE** cable to the **cellular port**.
2. Connect the **GPS** cable to the **GNSS port**.

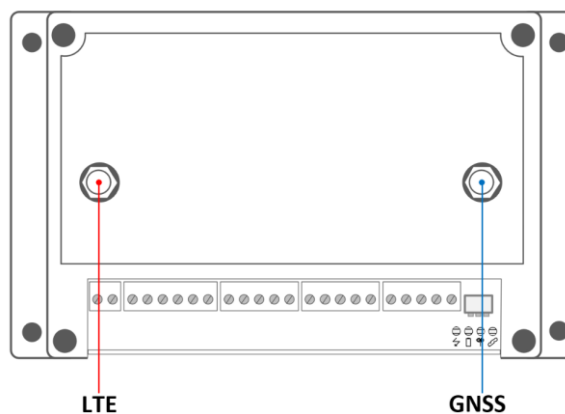

**Note:** For optimal cellular and GPS coverage, ensure that the antennas are mounted outside any electrical equipment enclosures, and have a clear sky view.

### Step 4/4A: Connect Gateway to Modbus Asset using RS485

Connect the **RS-485+** and **RS-485-** cabling from the asset to the **TxWireless EDGE IG20** using pins 15 & 16 on the terminal block..

Supply power by applying a voltage between 12VDC and 36VDC to the **PWR IN +** terminal block as shown in the diagram below.

**Warning:** Ensure the power polarity are correct before as incorrect input could cause damage.

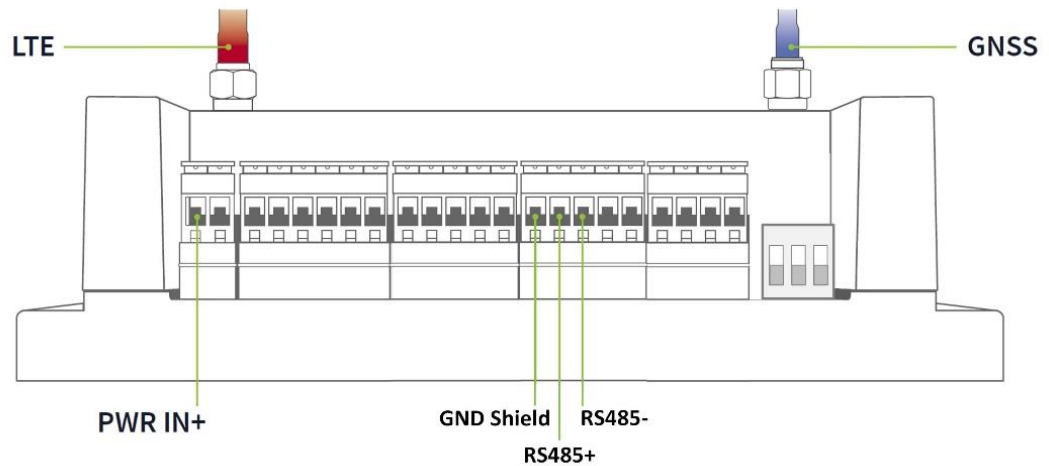

### Step 4/4B: Wire Asset Controller for CAN bus

Connect the CAN Low and CAN High cabling from the asset to the TxWireless EDGE IG20 using pins 17 & 18 on the terminal block.

Supply power by applying a voltage between 12VDC and 36VDC to the **PWR IN +** terminal block as shown in the diagram below.

**Warning:** Ensure the power polarity are correct before as incorrect input could cause damage.

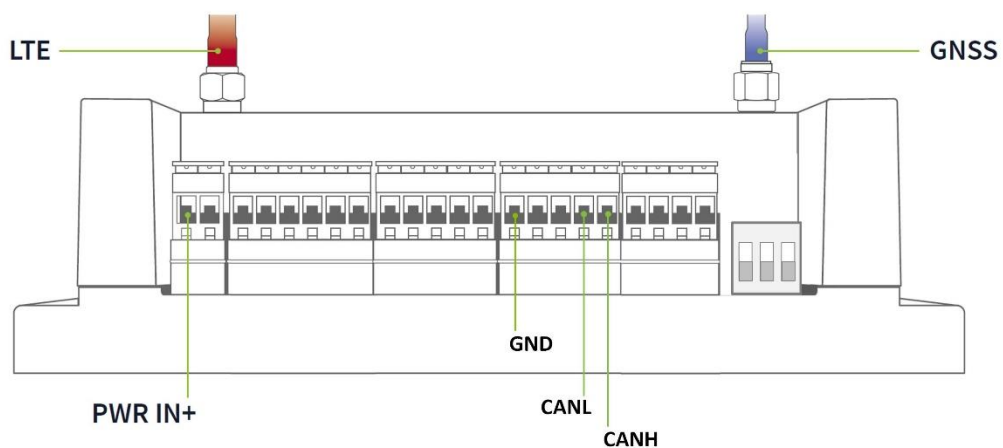

### 3. Additional sensors

#### Option 1: Wire Asset Controller to connect Analog Sensors

Connect the Sense and Ground cables from the Analog sensor to the TxWireless EDGE IG20 using either Pin9 or Pin10 along with Pin11(ADC GND) on the terminal block.

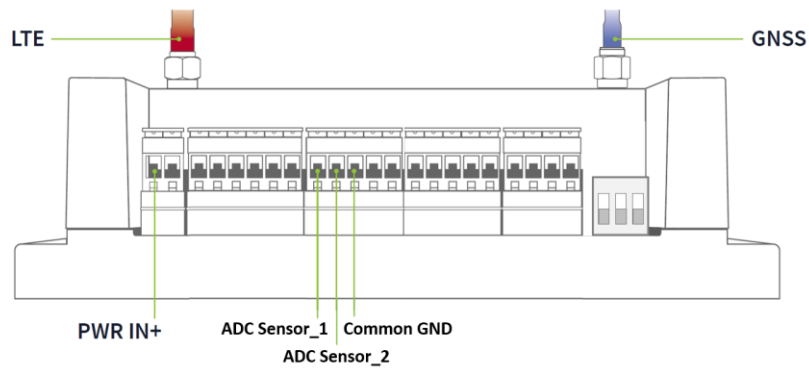

#### Option 2: Wire Asset Controller to connect Digital inputs

Connect the **General-Purpose DC input (+)** and **Common ground** cabling from the TxWireless EDGE IG20 to the GPI using the pin terminal blocks 7 or 8 & 14.

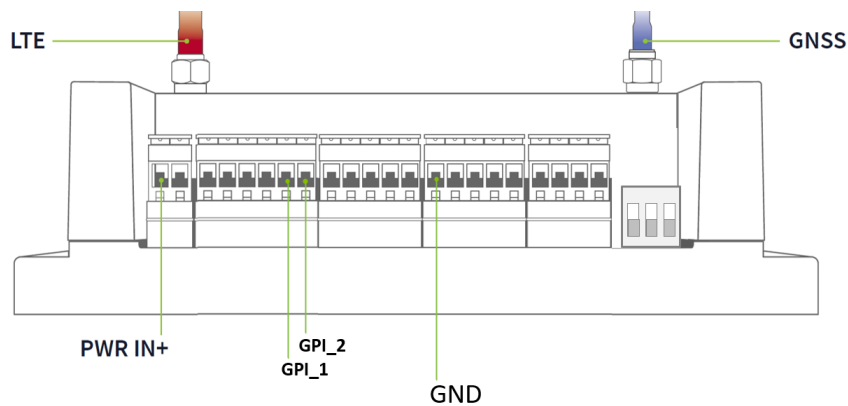

#### Option 3: Wire Asset Controller to connect Digital outputs

Connect your chosen output to the TxWireless EDGE IG20 using Pin3 or Pin4 and Pin6 (Out GND) on the terminal block. Note: The output voltage of both digital outputs is determined by the voltage applied to Pin5 (Out PWR IN+).

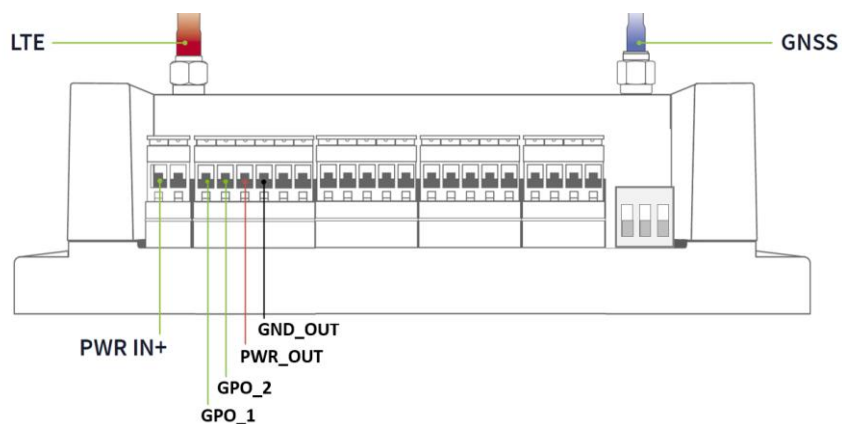

## Option 4: Wire Asset Controller to connect RS232

Connect the **RS-232 RX** and **RS-232 TX** cabling from the asset controller to the **TxWireless EDGE IG20** using the pin terminal blocks 12 & 13.

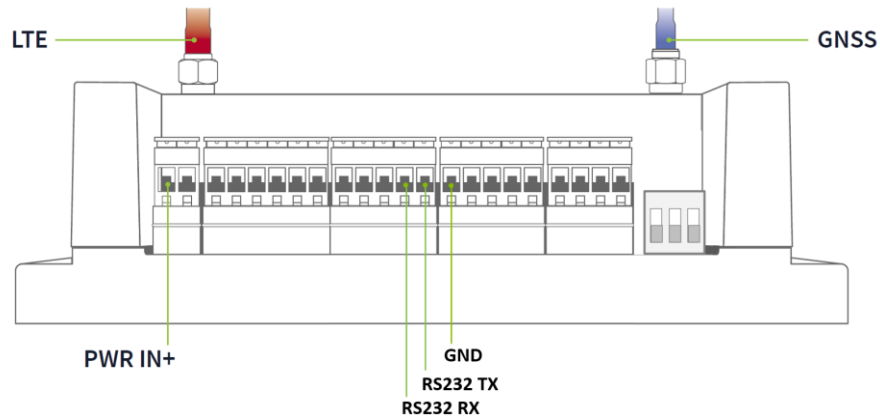

## Option 5: Wiring options for Onboard Relay

**DC Connection:** Connect the **External DC power** to pin terminal block 21 from the device to the **TxWireless EDGE IG20**. Connect the **Load** to pin terminal blocks 22. (Max: 28VDC – 5A)

**AC Connection:** Connect the **External AC power source** to pin terminal block 21 from the device to the **TxWireless EDGE IG20**. Connect the **Load** to pin terminal blocks 22. (Max: 277V – 5A)

**3V3 Connection:** Connect the **Load in** to pin terminal block 20 from the device to the **TxWireless EDGE IG20**. Connect the **load GND** to pin terminal blocks 19.

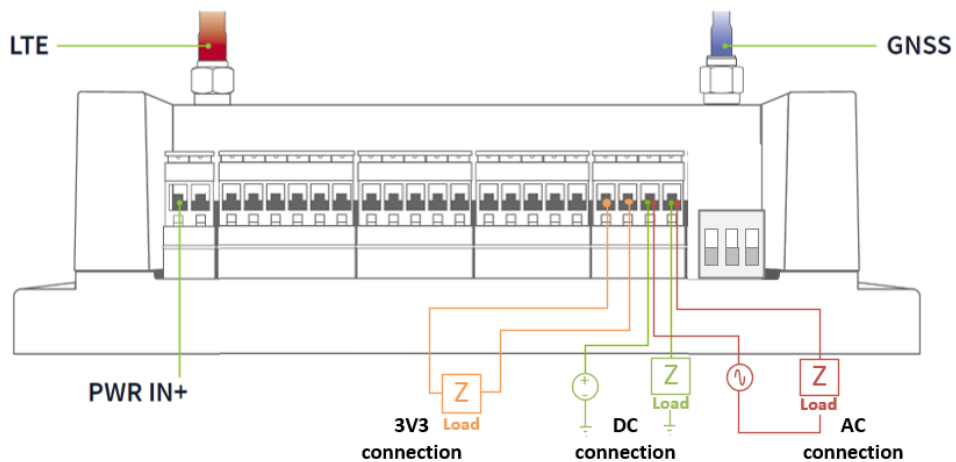



## 4. LED indicators

To aid the unit setup and troubleshooting process four LED indicators are visible from the front of the device. The image below shows the location of the LED indicators.

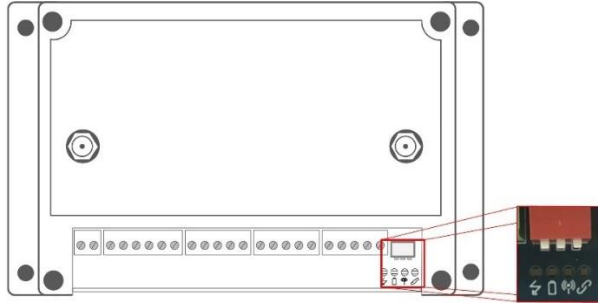

Each of the four LED indicators have an icon underneath them to show their function. The Table below shows their meaning.

Icon	Function
	External Power Status
	Battery Status
	Cellular Link Status
	Controller Link Status

The Indicator LED can operate in 5 different states.





- Off
- On
- Flashing at one flash per second.
- Flashing at one flash every 2 seconds.
- Flashing at one flash every 5 seconds.

The Table below shows the 25 possible LED combinations the LED's can be illuminated and a description of their meaning.

LED states				
Off	On	Flashing @ 1Hz	Flashing @ 0.5Hz	Flashing @ 0.5Hz

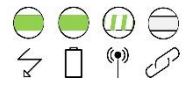
LED State	Sate Description
	No external power, no battery power.
	No external power, unit operating from internal battery, cell and asset not connected.
	No external power, unit operating from internal battery, active cell connection, asset not connected.

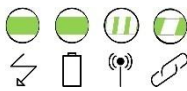
	No external power, unit operating from internal battery, cell not connected, searching for asset.
	No external power, unit operating from internal battery, active cell connection, searching for asset.
	No external power, unit operating from internal battery, cell not connected, asset connected.
	No external power, unit operating from internal battery, cell and asset connected.
	No external power, unit operating from internal battery @<30% capacity, cell and asset not connected.
	No external power, unit operating from internal battery @<30% capacity, active cell connection, asset not connected.
	No external power, unit operating from internal battery @<30% capacity cell not connected, searching for asset.
	No external power, unit operating from internal battery @<30% capacity, active cell connection, searching for asset.
	No external power, unit operating from internal battery @<30% capacity, cell not connected, asset connected.
	No external power, unit operating from internal battery @<30% capacity, active cell connection, asset connected.
	External power, battery charged, cell and asset not connected.
	External power, battery charged, active cell connection, asset not connected.
	External power, battery charged, cell not connected, searching for asset.
	External power, battery charged, active cell connection, searching for asset.
	External power, battery charged, cell not connected, asset connected.
	External power, battery charged, active cell connection, asset connected.

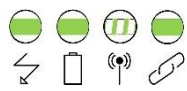
	External power, battery charging, cell and asset not connected.
	External power, battery charging, active cell connection, asset not connected.
	External power, battery charging, cell not connected, searching for asset.
	External power, battery charging, active cell connection, searching for asset.
	External power, battery charging, cell not connected, asset connected.
	External power, battery charging, active cell connection, asset connected.

## 5. Termination switches

The TxWireless IG20 is equipped integrated termination resistors for the RS485 (MODBUS) and CAN bus interfaces. These resistors can be switched in and out using the user accessible DIP switch on the front of the unit.

### RS485 Termination Resistor

The RS485 termination switch will place a 120 ohm resistor across the RS485+ and RS485- lines as illustrated in Figure 1.

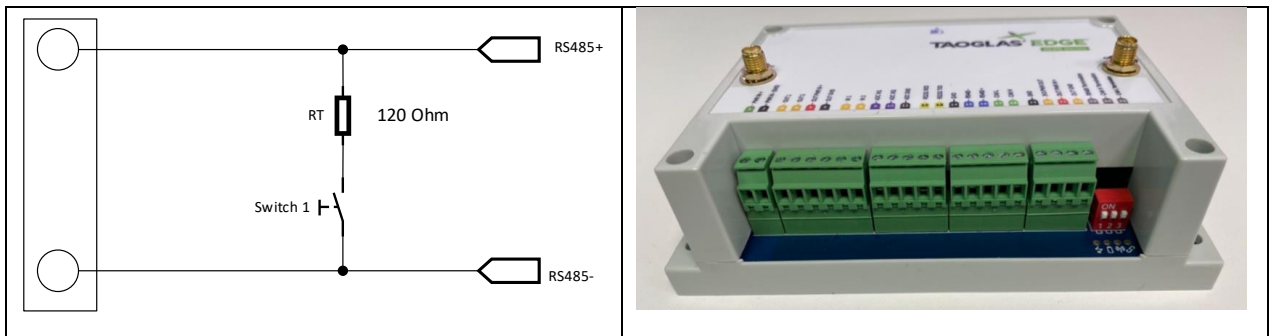

Figure 1 RS485 Termination switch circuit

In Figure 1, Switch 1 is dedicated to the RS485 termination switch circuit. Figure 2 below details the effect of the switch.

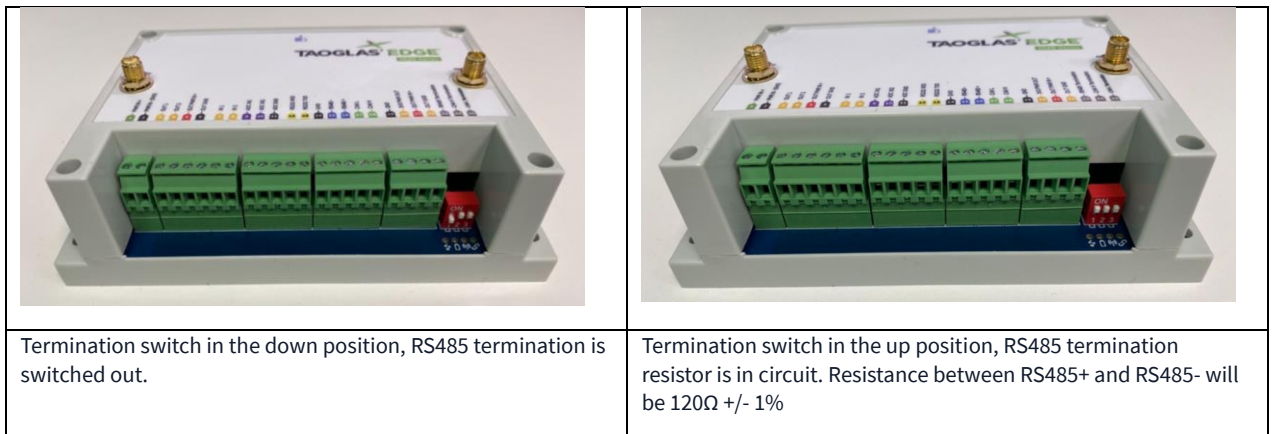

Figure 2 RS485 termination resistor operation

## CAN Bus Termination Resistors

The CAN Bus Termination is a Split termination design consisting of 2x 60Ω resistors arranged as shown in the schematic below. The split termination was chosen as it has better EMC performance than a standard termination. Switches 2 and 3 on the DIP switch control the CAN bus termination.

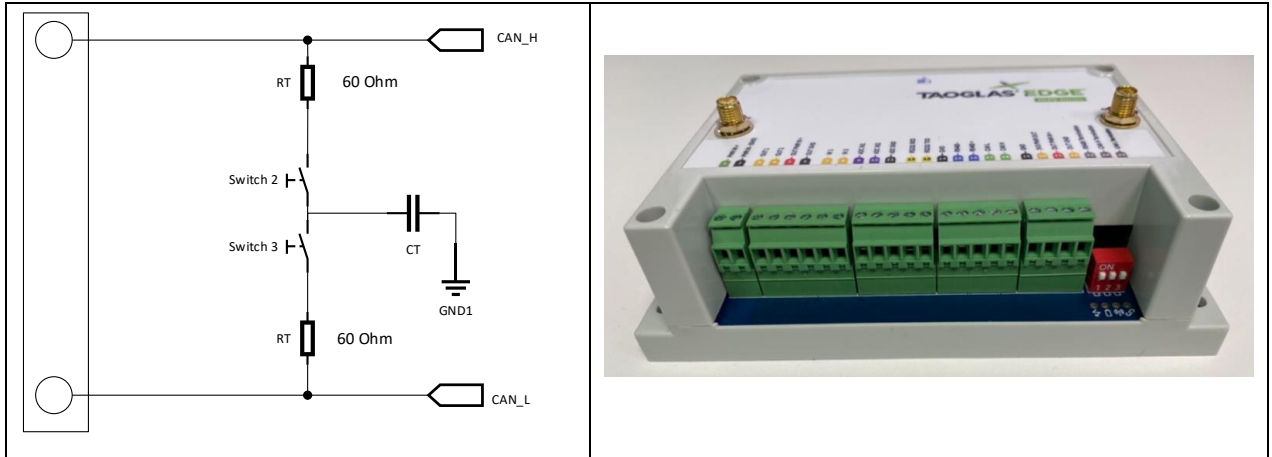
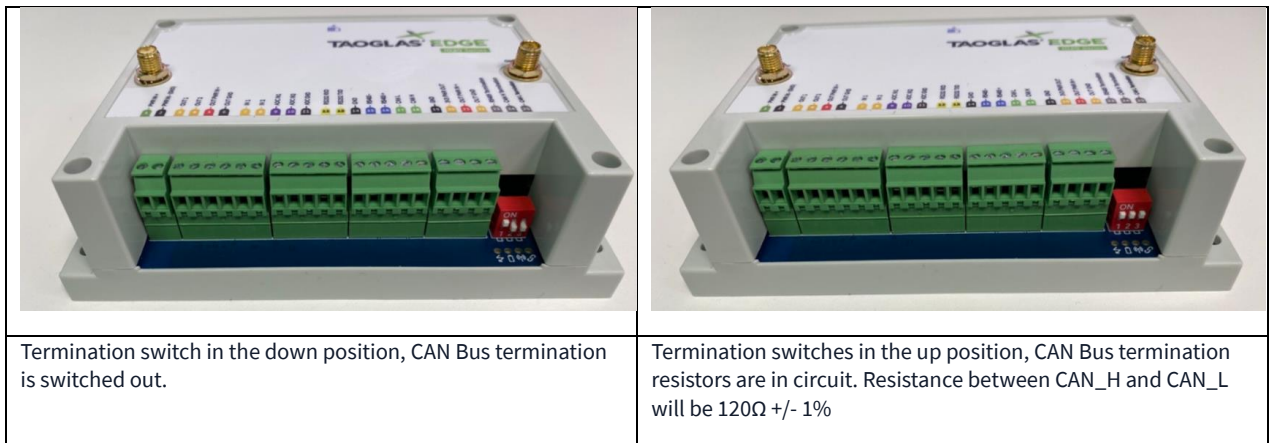

Figure 3 CAN Bus Split termination schematic



## 6. Appendix

### 6.1 Security

The EDGE Industrial Gateway device security is provided by four mechanisms:

1. Connection to the Cloud-based components via HTTPS, with the servers public certificates held on the EDGE Industrial Gateway device.
2. Authentication of the device by the TxWireless Insights Platform, with the unique and individual private key held securely in a cryptographic coprocessor.
3. Whitelisting of the domains to which the EDGE Industrial Gateway APN can connect – TxWireless Insights and TxWireless Insights Platform and NTP servers only.
4. The device periodically reports its configuration hash (security), firmware versions, and certificate bundle version to the TxWireless Insights Platform. A report is sent each time a device is powered up, or when the configuration, certificate, or firmware has changed.

---

## 6.2 Safety and Regulatory Requirements

**Warning:** Failure to follow instructions could increase risk to safety and noncompliance with regional laws and regulations.

**Warning: DO NOT SHORT CIRCUIT, DISASSEMBLE, CRUSH, PENETRATE OR INCINERATE.**

**BATTERY MAY LEAK OR EXPLODE IF HEATED ABOVE 100 °C (212 °F).**

**Warning: HAZARDOUS AREA WARNING:** This instrument has not been designed to be intrinsically safe for use in areas classified as hazardous locations. For your safety, DO NOT use it in hazardous (classified) locations.

**Caution:** In the case of an emergency, degraded performance will occur if wireless reception is inhibited.

**Note:** The device has an operating range between -20°C (-4F) to +60°C (140F).

The device can be safely charged in an ambient temperature range of between 0 – 40 degrees Celsius (32-104 degrees Fahrenheit).

**Note:**

- a) Do not disassemble or open crush, bend or deform, puncture or shred.
- b) Do not modify or remanufacture, attempt to insert foreign objects into the battery, immerse or expose to water or other liquids, expose to fire, explosion, or other hazards.
- c) Only use the battery for the system for which it is specified.
- d) Only use the battery with a charging system that has been qualified with the system per CTIA Certification Requirements for Battery System Compliance to IEEE 1725. Use of an unqualified battery or charger may present a risk of fire, explosion, leakage, or other hazards.
- e) Do not short circuit a battery or allow metallic conductive objects to contact battery terminals.
- f) Replace the battery only with another battery that has been qualified with the system per this standard, IEEE-Std-1725. Use of an unqualified battery may present a risk of fire, explosion, leakage, or other hazards. Only authorized service providers shall replace battery. (If the battery is non-user replaceable).
- g) Promptly dispose of used batteries in accordance with local regulations.
- h) Battery usage by children should be supervised.
- i) Avoid dropping this device or battery. If this device or battery is dropped, especially on a hard surface, and the user suspects damage, take it to a service center for inspection.
- j) Improper battery use may result in a fire, explosion, or other hazards.

**Caution:** Risk of explosion if battery is replaced by an incorrect type. Dispose of used batteries according to the instructions.

### Federal Communication Commission Interference Statement

This device complies with part 15 of the FCC Rules. Operation is subject to the following two conditions: (1) This device may not cause harmful interference, and (2) this device must accept any interference received, including interference that may cause undesired operation.

This device has been tested and found to comply with the limits for a Class B digital device, pursuant to Part 15 of the FCC Rules. These limits are designed to provide reasonable protection against harmful interference in a residential installation. This equipment generates, uses, and can radiate radio frequency energy, and, if not installed and used in accordance with the instructions, may cause harmful interference to radio communications. However, there is no guarantee that interference will not occur in a particular installation. If this equipment does cause harmful interference to radio or television reception, which can be determined by turning the equipment off and on, the user is encouraged to try to correct the interference by one or more of the following measures:

- Reorient or relocate the receiving antenna.
- Increase the separation between the equipment and receiver.
- Connect the equipment into an outlet on a circuit different from that to which the receiver is connected.
- Consult the dealer or an experienced radio/TV technician for help.

### FCC Caution:

- Any changes or modifications not expressly approved by the party responsible for compliance could void the user's authority to operate the equipment.
- The antenna(s) used for this transmitter must not be co-located or operating in conjunction with any other antenna or transmitter.

### RF Exposure Information (SAR)

This device meets the government's requirements for exposure to radio waves. This device is designed and manufactured not to exceed the emission limits for exposure to radio frequency (RF) energy set by the Federal Communications Commission of the U.S. Government.







The exposure standard for wireless device employs a unit of measurement known as the Specific Absorption Rate, or SAR. The SAR limit set by the FCC is 1.6W/kg. \*Tests for SAR are conducted using standard operating positions accepted by the FCC with the device transmitting at its highest certified power level in all tested frequency bands. Although the SAR is determined at the highest certified power level, the actual SAR level of the device while operating can be well below the maximum value. This is because the device is designed to operate at multiple power levels so as to use only the power required to reach the network. In general, the closer you are to a wireless base station antenna, the lower the power output. The highest SAR value for the model device as reported to the FCC when worn on the body, as described in this user guide, is 1.1 W/Kg (Body-worn measurements differ among device models, depending upon available accessories and FCC requirements).

While there may be differences between the SAR levels of various devices and at various positions, they all meet the government requirement.

The FCC has granted an Equipment Authorization for this model device with all reported SAR levels evaluated as in compliance with the FCC RF exposure guidelines. SAR information on this model device is on file with the FCC and can be found under the Display Grant section of [www.fcc.gov/oet/ea/fccid](http://www.fcc.gov/oet/ea/fccid) after searching on FCC ID: WYPEU0312.

For body worn operation, this device has been tested and meets the FCC RF exposure guidelines for use with an accessory that contains no metal and be positioned a minimum of 1 cm from the body. Use of other accessories may not ensure compliance with FCC RF exposure guidelines.

### Notices

-  **Warning**  
DO NOT SHORT CIRCUIT, DISASSEMBLE, CRUSH, PENETRATE OR INCINERATE.
-  **Warning**  
BATTERY MAY LEAK OR EXPLODE IF HEATED ABOVE 100 °C (212 °F).
-  **Warning**  
**HAZARDOUS AREA WARNING:** This instrument has not been designed to be intrinsically safe for use in areas classified as hazardous locations. For your safety, DO NOT use it in hazardous (classified) locations.
-  **Warning**  
Do not operate the transmitter when someone is within 20 cm of the antenna.  
Do not operate the equipment in an explosive atmosphere.
-  **Caution**  
To comply with FCC RF Exposure requirements in section 1.1310 of the FCC Rules, antennas used with this device must be installed to provide a separation distance of at least 20 cm from all persons to satisfy RF exposure compliance.
-  **European Waste Electronic Equipment Directive 2002/96/EC**  
Please ensure that your old Waste Electricals and Electronics are recycled do not throw them away into standard waste.





[txwireless.com](http://txwireless.com)

---